

支持的设备型号
Supported Models

HCQX-AD04-D4 HCQX-AD04-D4-C HCQX-TS04-D4
HCQX-DA04-D4 HCQX-DA04-D4-C



禾川科技官方网站

HPPP2030000-00B
Date 2024-06-03
CN 安装说明
EN Instruction Sheet

1. 安全注意事项 (Safety precautions)

本说明书涉及产品均为开放型外壳设计。要求用户使用产品时，务必将产品安装于具有防尘、防潮以及免于电击/冲击等意外的控制柜内，并且需要设置保护措施以防止非维护人员不当操作或意外导致设备故障或损坏，造成不可避免的人员危险和财产损失。

The products involved are all open-type housing designs. Therefore they should be installed in a control cabinet that is free of airborne dust, humidity, electric shock, and vibration. The cabinet should prevent non-maintenance staff from operating the products or accidents from happening in case danger and damage may occur on the products.

更详细的信息请参考 QX 系列硬件手册。

Please refer to the QX series hardware manual for more detailed information.

2. 通用电气及环境规格 (General electrical and environmental specifications)

2.1 通用电气规格 (General electrical specifications)

型号 (Model)	额定功率: W	Rated power: W	额定电压	Rated voltage
HCQX-AD04-D4	1.2	1.2	DC24V, 电压范围: DC20.4~28.8V	DC24V, voltage range: DC20.4~28.8V
HCQX-DA04-D4				
HCQX-AD04-D4-C				
HCQX-DA04-D4-C				
HCQX-TS04-D4			DC12V, 无需外部供电	DC12V, no external power supply required

*注: 所有型号均为安全特低电压输入产品。

*Note: All models are featured by the SELV input type.

2.2 环境规格 (Environmental requirements)

项目	Item	规格	Specifications
海拔高度	Altitude	≤2000m	≤2000m
使用环境	Operating environment	控制柜内安装, 开放式及室内使用	Installation within a control cabinet, open-type and indoor use
工作温度	Operating temperature	-10~55°C	-10~55°C
储存温度	Storage temperature	-40~75°C	-40~75°C
环境湿度	Ambient humidity	10~95%RH (无结露)	10~95%RH (non-condensation)
振动耐受	Vibration resistance	5~150Hz (X/Y/Z方向, 1g/3.5mm位移)	5~150Hz (X/Y/Z direction, 1g /3.5mm displacement)
污染等级	Pollution degree	污染度II	Level 2
冷却方式	Cooling method	自然冷却	Natural air cooling
防护等级	IP rating	IP20	IP20
外壳材质	Enclosure material	阻燃材料	Self-extinguishable

*注: 如果以制造商未规定的方式使用设备, 可能会损坏设备。

*Note: The equipment may be damaged if used in a manner not specified by the manufacturer.

3. 安装说明 (Installation instructions)

3.1 控制柜安装 (Installation within a control cabinet)

CN 设备冷却方式为自然冷却或通过加装风扇进行冷却, 请保证安装方向与柜壁垂直;
请参考右侧示意图, 在设备的周围留有足够的空间, 并排安装时, 建议横向两侧预留
20mm 以上间距。

EN Please install the product perpendicular to the wall and ensure a sufficient cooling effect via natural air or a cooling fan. Please leave enough clearance around the product as shown in the right figure. During a side-by-side installation, please leave a horizontal clearance of more than 20 mm on both sides.

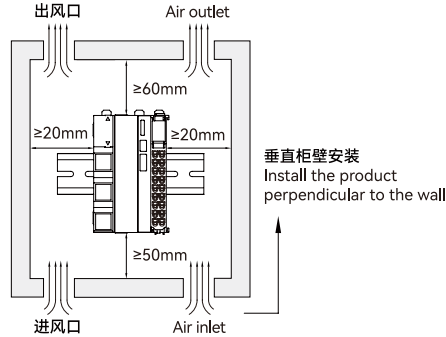

3.2 导轨拆装 (DIN rail mounting and dismounting)

CN 安装模块时, 将模块侧面导槽对准 Q 系列控制器导槽后, 向内按压模块, 听到“咔哒”声, 模块成功安装于 DIN 导轨上 (安装前保证双向联动卡扣处于紧锁状态, 否则可能导致安装故障); 拆卸模块时, 将卡扣向上拉动一定距离, 听到“咔哒”声后, 取下模块即可。

EN Before installation, check that the DIN rail mounting latch is in a locked state. During mounting, align the groove of the module to that of the Q series controller to engage them together, and then press the module towards the DIN rail until a clear click is heard (which indicates the latch is momentarily opened and locked onto the rail). During dismounting, pull the latch upwards until a clear click is heard (which indicates the latch is unlocked), and then directly remove the module.

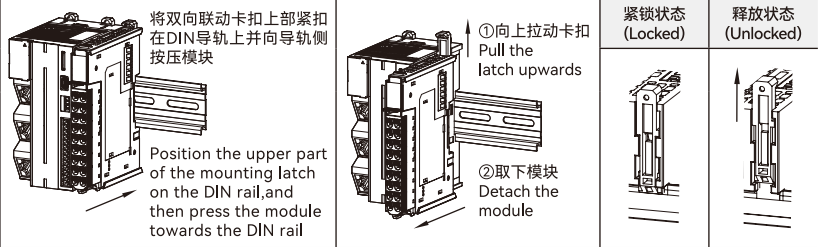

3.3 可拆卸端子拆装 (Removable terminal block mounting and dismounting)

CN 安装可拆卸端子时, 将端子底部对准模块底部凹槽并紧扣, 上部对齐模块, 当听到“咔哒”声即完成了端子的组装; 拆卸端子时, 向下按压端子顶部卡扣, 使其脱离模块本体并以底部卡扣呈圆弧状斜向下施力, 将端子取下。

EN During mounting, align the mounting hook at the bottom of the terminal block to the groove of the module and press inwards until a clear click is heard (which indicates the terminal block has been locked to the module). During dismounting, press the lock lever on the terminal block and then detach it from the module.

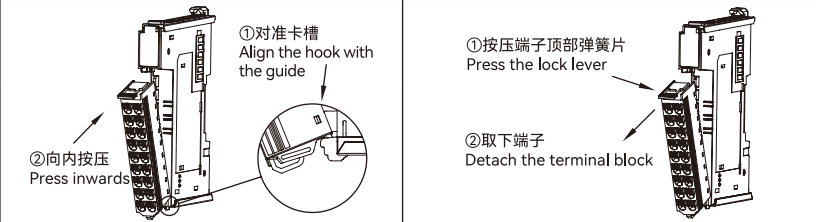

3.4 线缆拆装 (Cable connecting and disconnecting)

CN 安装线缆时，将赠送的一字螺丝刀垂直插入可拆卸端子压块内，施加超过 30N 的力，将准备好的线缆插入到圆孔中，拔出一字螺丝刀，轻拽线缆，线缆不松动即成功完成配线；反之即可取出线缆。端子规格及配线示意图如右图所示。

EN During connecting, insert the flat-blade screwdriver into the unlocking tab with a force of more than 30 N. Then insert a cable into the circular hole. Gently tug the cable after pulling out the screwdriver. If the cable is secured firmly, then the connection is finished. The reverse is the procedure for unplugging the cable. The terminal specifications and wiring diagram are shown in the right figure.

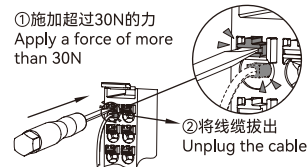
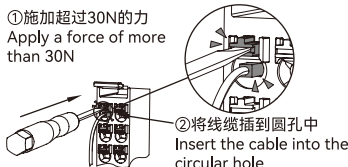

模块端子 (Terminal)	线径范围: AWG (Wire width)	剥线长度: mm (Wire stripping length)	按压力: N (Pressure)	拔线力: N (Wire pulling force)
18Pin	24~17	8~9	30	50

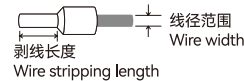

警告：仅使用铜导线。

Warning: Use copper conductors only.

Attention: Utilisez uniquement des conducteurs en cuivre.

4. 接口和尺寸说明 (Interface and dimension description)

序号(No.)	项目	Item
1	产品型号	Product model
2	模块状态指示灯	Module status indicator
3	18Pin IO端子	18Pin IO terminal
4	双向联动卡扣	DIN rail mounting latch
5	扩展模块通讯接口	Expansion module communication interface
6	侧边丝印	Side silk screen printing
7	集线结构	Cable collector
8	标签	Label

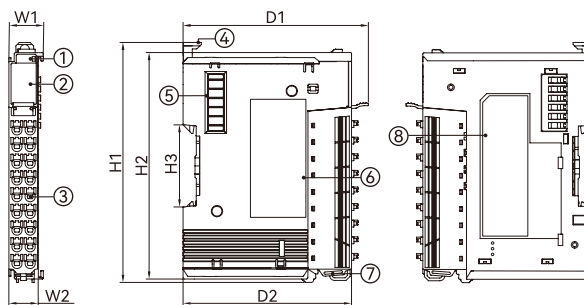

型号 (Model)	外形尺寸 (Dimension) : mm							重量 (Weight) : g
	W1	W2	H1	H2	H3	D1	D2	
HCQX-AD04-D4	15.20	13.00	106.00	100.00	35.40	81.90	74.50	70 approx.
HCQX-DA04-D4								
HCQX-AD04-D4-C								
HCQX-DA04-D4-C								
HCQX-TS04-D4								

5. 指示灯说明 (Indicator description)

指示灯含义 (Indicator meaning)	颜色 (Color)	状态 (Status)	说明 (Description)
模块状态 (Module status)	黄色 (Yellow)	熄灭 Not lit	Init (初始化状态) Initialization
	黄色 (Yellow)	快闪 Fast blinking	Preop (预操作状态) Pre Operational
		慢闪 Slow blinking	Safeop (安全操作状态) Safe Operational
		常亮 Lit	OP (可操作状态) Operational
		双闪 Double blinking	Boot (引导程序状态) Bootstrap
红色 (Red)	慢闪 Slow blinking	总线信号输入状态异常 The module is in an abnormal state	

丝印 (Screen printing)	指示灯含义 (Indicator meaning)	颜色 (Color)	状态 (Status)	说明 (Description)
AD04-D4/AD04-D4-C				
V N (1~4)	通道状态 (Channel status)	绿色 (Green)	熄灭 Not lit	通道 N 电压模式未使能 The voltage mode of channel N is not enabled
		常亮 Lit	通道 N 电压模式使能 The voltage mode of channel N is enabled	
I N (1~4)	通道状态 (Channel status)	绿色 (Green)	熄灭 Not lit	通道 N 电流模式未使能 The current mode of channel N is not enabled
		常亮 Lit	通道 N 电流模式使能 The current mode of channel N is enabled	
E N (1~4)	通道状态 (Channel status)	红色 (Red)	熄灭 Not lit	通道 N 无错误发生 No error occurs in channel N
		常亮 Lit	通道 N 有错误发生 An error occurs in channel N	

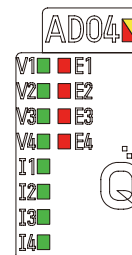

丝印 (Screen printing)	指示灯含义 (Indicator meaning)	颜色 (Color)	状态 (Status)	说明 (Description)
DA04-D4/DA04-D4-C				
V N (1~4)	通道状态 (Channel status)	绿色 (Green)	熄灭 Not lit	通道 N 电压模式未使能 The voltage mode of channel N is not enabled
		常亮 Lit	通道 N 电压模式使能 The voltage mode of channel N is enabled	
I N (1~4)	通道状态 (Channel status)	绿色 (Green)	熄灭 Not lit	通道 N 电流模式未使能 The current mode of channel N is not enabled
		常亮 Lit	通道 N 电流模式使能 The current mode of channel N is enabled	
E N (1~4)	通道状态 (Channel status)	红色 (Red)	熄灭 Not lit	通道 N 无错误发生 No error occurs in channel N
		常亮 Lit	通道 N 有错误发生 An error occurs in channel N	

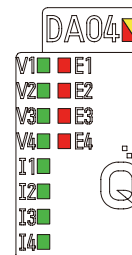

TS04-D4

T N (1~4)	绿色 (Green)	 熄灭 Not lit	通道 N 当前未选用热电偶传感器	Channel N is not currently connected to a thermocouple sensor
		 常亮 Lit	通道 N 当前选用的是热电偶传感器	Channel N is currently connected to a thermocouple sensor
P N (1~4)	绿色 (Green)	 熄灭 Not lit	通道 N 当前未选用热电阻传感器	Channel N is not currently connected to an RTD sensor
		 常亮 Lit	通道 N 当前选用的是热电阻传感器	Channel N is currently connected to an RTD sensor
E N (1~4)	红色 (Red)	 熄灭 Not lit	通道 N 无错误发生	No error occurs in channel N
		 常亮 Lit	通道 N 有错误发生	An error occurs in channel N

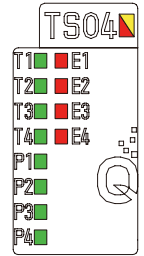





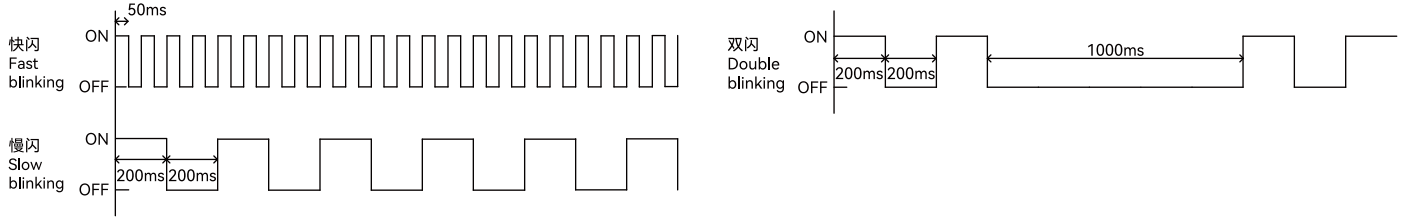





















指示灯闪烁频率如下图所示:

The indicator blinking frequency is shown below.



6. 端子及配线说明 (Terminal and wiring description)

HCQX-AD04-D4/HCQX-AD04-D4-C				接线 (Wiring)	
V1+	0		10	V1-	<p>两线制: Two-wire:</p>
I1+	1		11	I1-	
V2+	2		12	V2-	
I2+	3		13	I2-	
V3+	4		14	V3-	
I3+	5		15	I3-	
V4+	6		16	V4-	
I4+	7		17	I4-	
24V	8		18	0V	
HCQX-DA04-D4/HCQX-DA04-D4-C				接线 (Wiring)	
V1+	0		10	AGND	
I1+	1		11	AGND	
V2+	2		12	AGND	
I2+	3		13	AGND	
V3+	4		14	AGND	
I3+	5		15	AGND	
V4+	6		16	AGND	
I4+	7		17	AGND	
24V	8		18	0V	
HCQX-TS04-D4				接线 (Wiring)	
A1/TC1+	0		10	B1/TC1-	<p>两线制: Two-wire:</p> <p>三线制: Three-wire:</p>
B1	1		11	NC	
A2/TC2+	2		12	B2/TC2-	
B2	3		13	NC	
C+	4		14	C-	
A3/TC3+	5		15	B3/TC3-	
B3	6		16	NC	
A4/TC4+	7		17	B4/TC4-	
B4	8		18	NC	

*注: 外部冷端电阻出厂默认安装。

*Note: External cold-junction compensation resistor (factory default installation).